

In-tensive

ePOXIA

Inno started manufacturing personal looking and timeless products that stand out of the mass in 1975. Today Inno is known of it's internationally awarded collection. Inno develops innovative products of high quality to meet the most demanding requirements of public interiors.

"We strongly believe that a good product has to give more than a look and a function, it has to feel right".

www.inno.fi



TOOLS FOR ARCHITECTS

Functionality and timeless elegance are tied together with modular simplicity. The highly versatile meeting table system In-tensive is extremely flexible and adapts to various interiors. In-tensive is your key to a successful meeting furnishing project, be it in modern or classic style.

Offering solutions for different conference needs, the main features include modular structure, table tops in different shapes, sizes and materials and a large variety of leg versions. All In-tensive tables have a spacious cable tray for easy cable management and hiding conference equipment. The tray is accessed through hinged flaps. When closed, these flaps will leave a gap for distribution of cables keeping unnecessary equipment out of sight.

In-tensive is awarded with the Muuz International Design Award 2015.

The designer interior architect Jouni Leino founded his design studio in 1992 and has since developed projects mostly for public spaces and offices. His co-operation with Inno has been long and successful.



INSPIRATION





Chairs: Lab, Design: Harri Korhonen



Chairs: Kola, Design: Mikko Laakonen



Chairs: Select, Design: Harri Korhonen

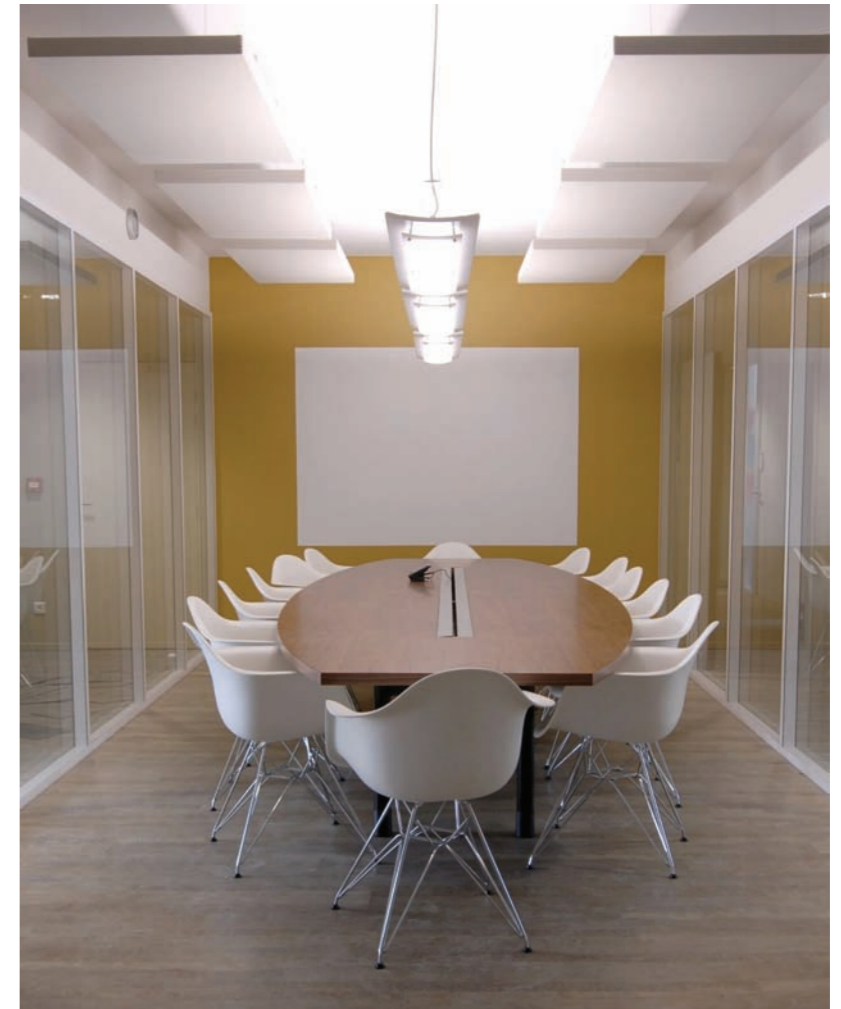

ROUND TABLES



Chairs: Select, Design: Harri Korhonen



LEG OPTIONS



Frame leg



Frame leg with covers



Wooden frame leg

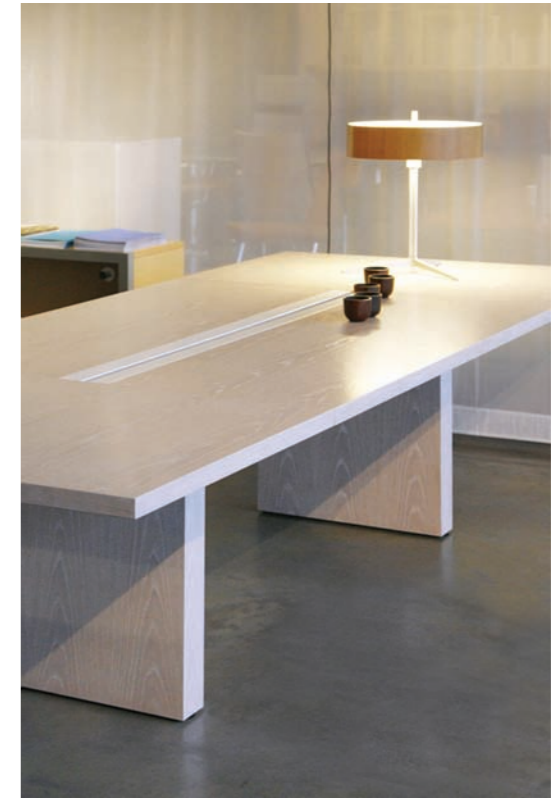

Cover leg



Metal leg



Metal leg with wheels



Wood leg

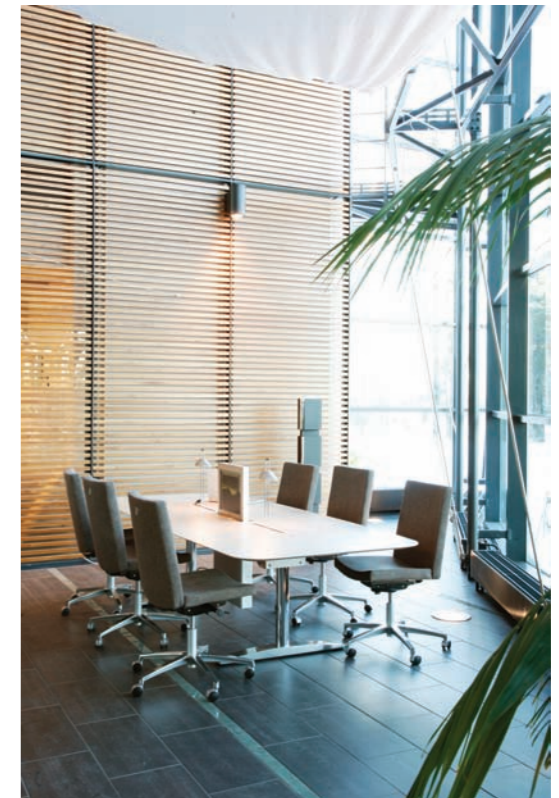

T leg

STANDARD MATERIALS

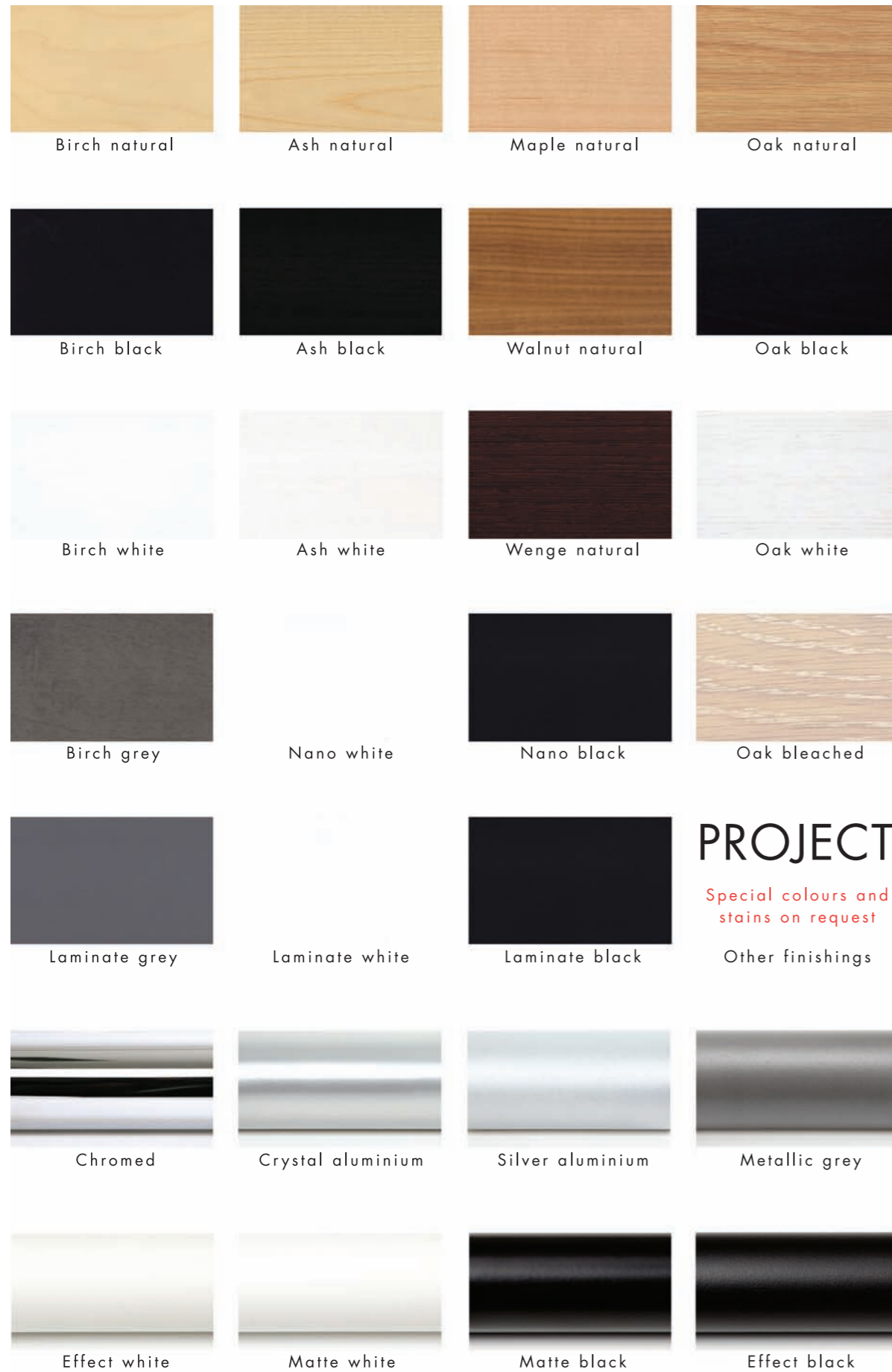

SELECTED COLOURS



In addition to standard materials four selected colours are available for metal and ash.

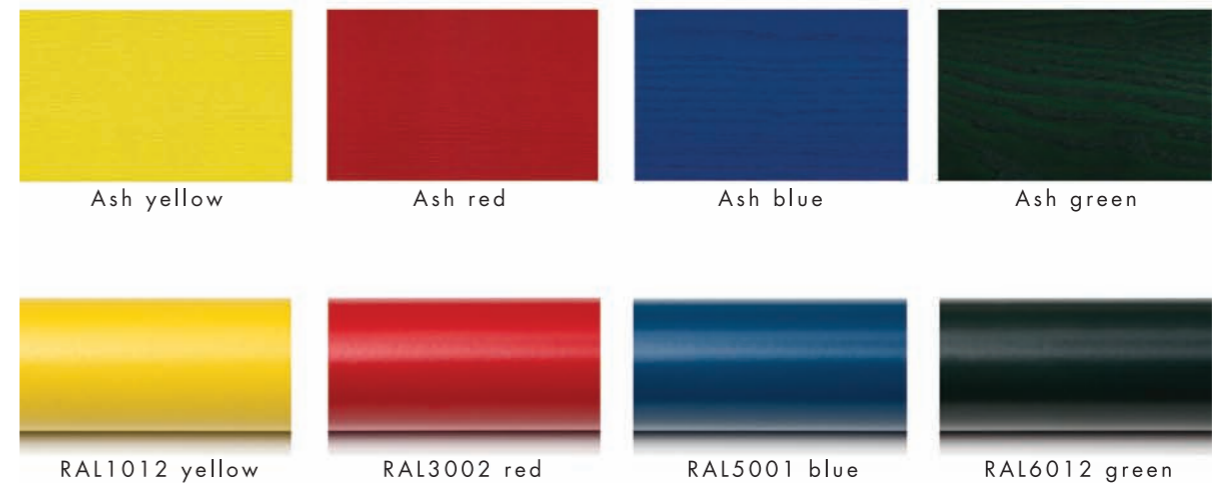

MODULAR SOLUTIONS



Custom extension



Folding version (custom request)



Unit tables with connector



Chairs: Select, Design: Harri Korhonen



Chairs: Basso, Design: Harri Korhonen

CUSTOM SOLUTIONS

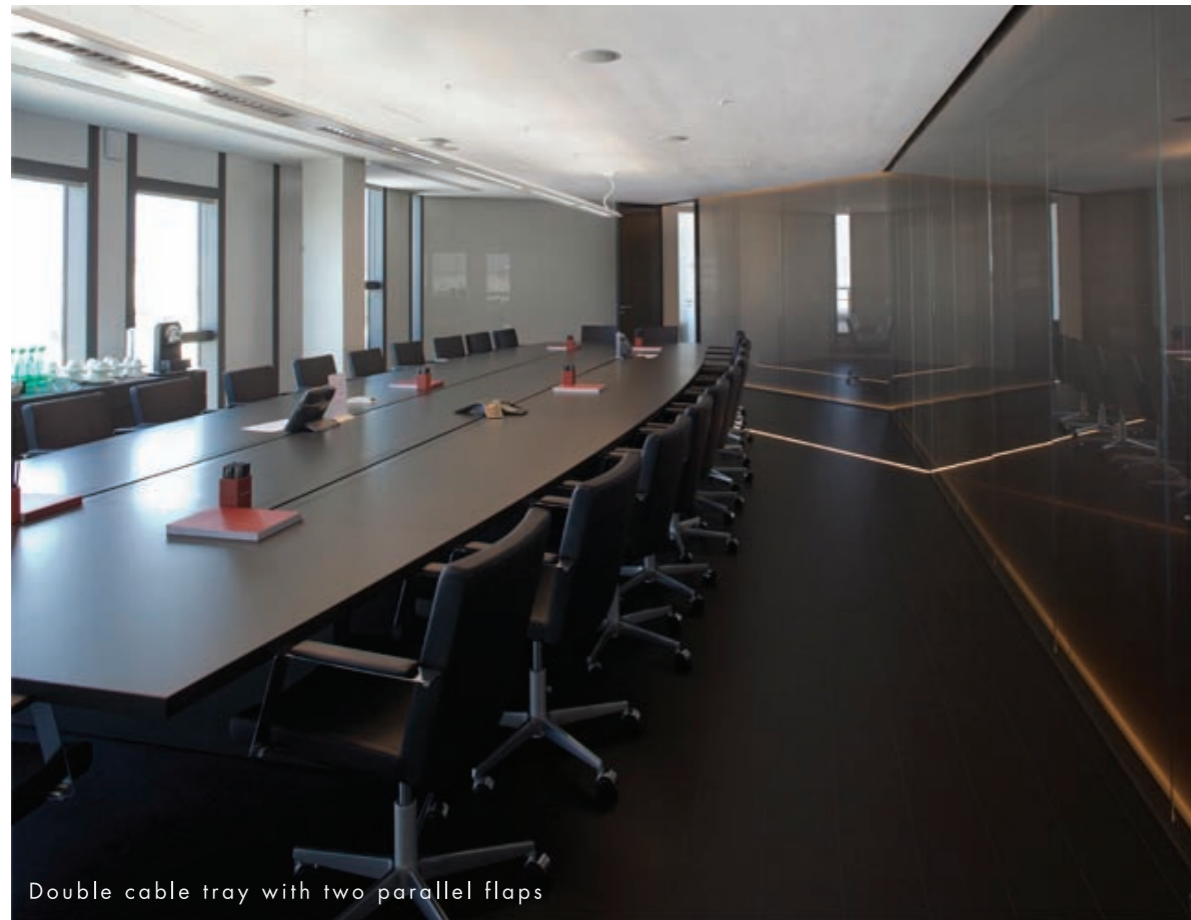

Double cable tray with two parallel flaps



Integrated microphones



U shaped table with modesty panels



Flush mounting

CABLE MANAGEMENT

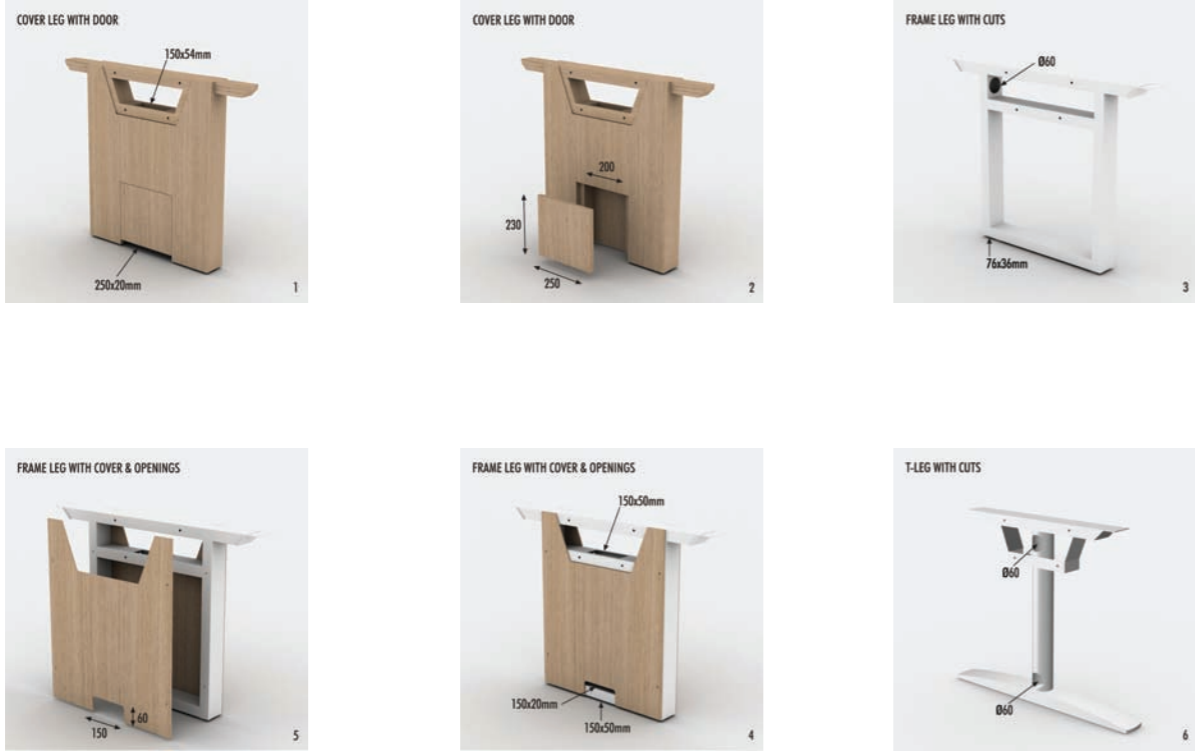

Options for routing cables to the table, incl. cuts and panels in legs, cable totems and tubes.

Second level as an option to hide cables and to install electric/data components.

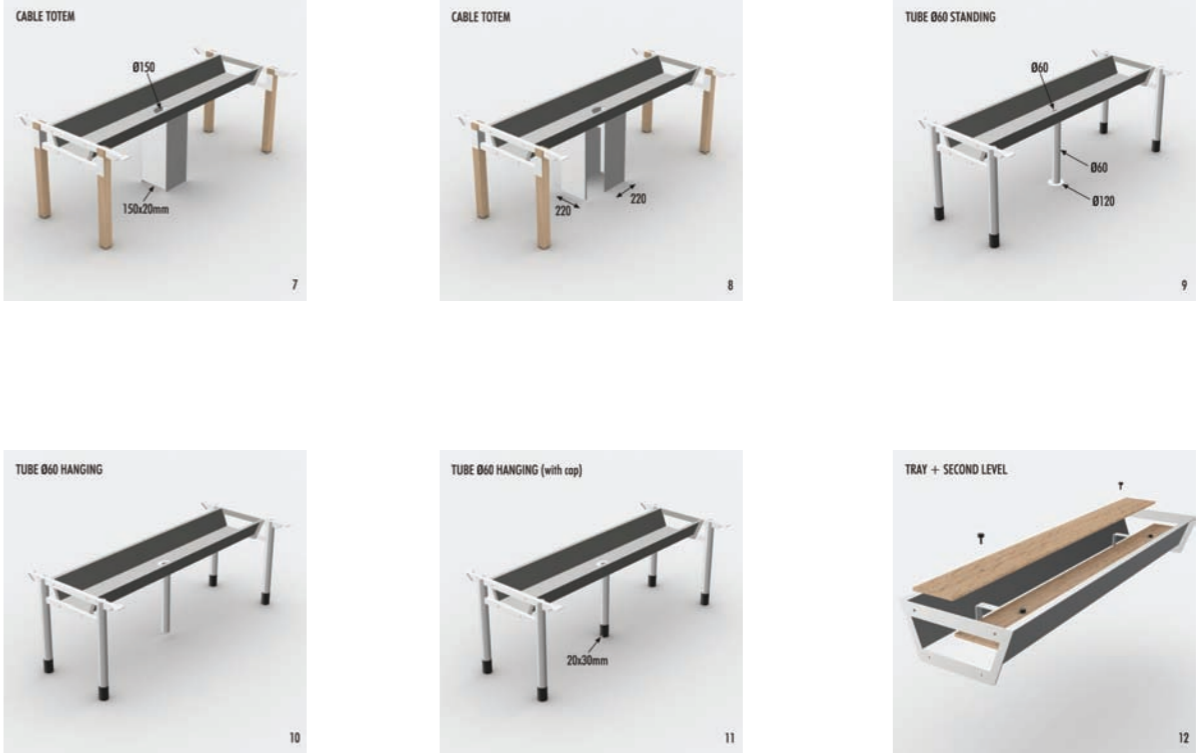

SPECIFICATIONS

STANDARD 1200 / 1500 WIDE

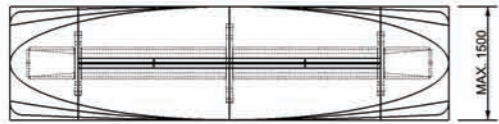

MAX. 2000 WIDE

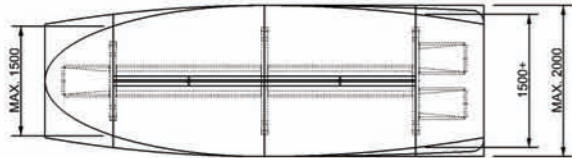

2000+ WIDE (DOUBLE CABLE TRAY)

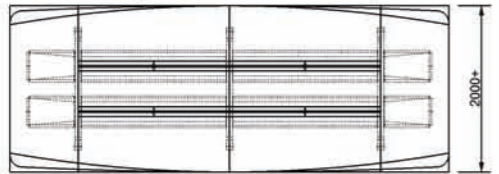

VISIOCONFERENCE

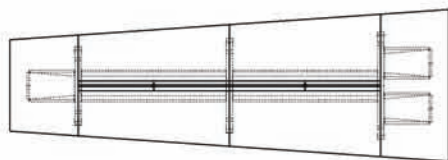

Ø 3000+

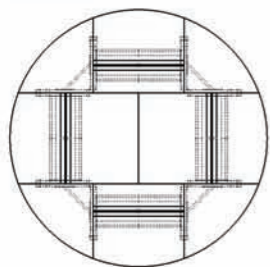

Ø 2500-2900

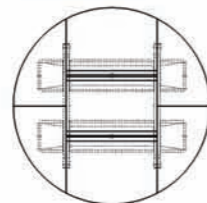

Ø 2000-2400

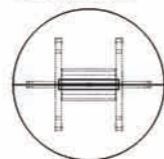

CORNER SOLUTION

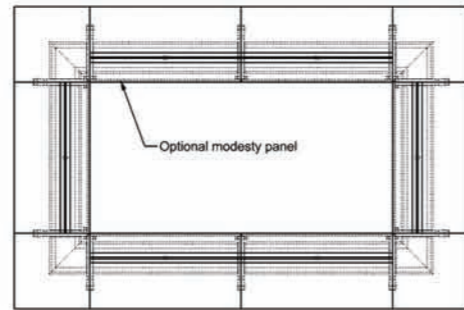

MODULAR SOLUTIONS

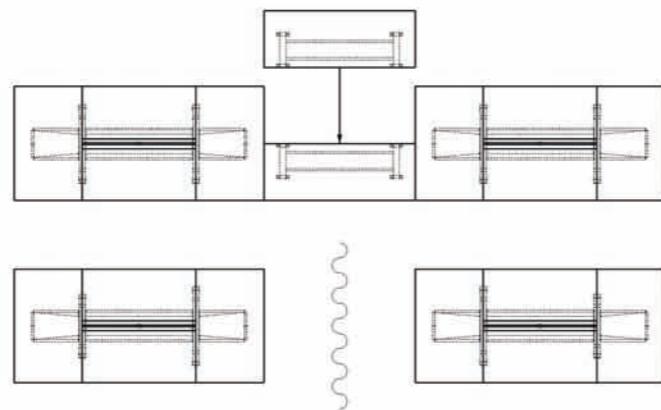
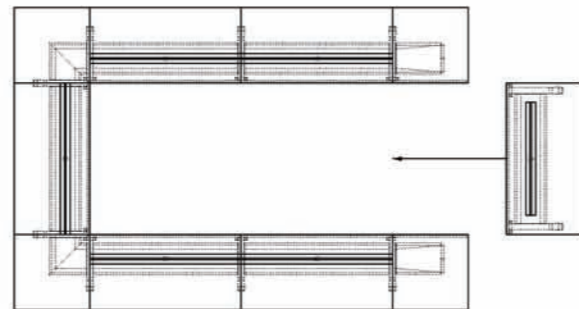

Recommended minimum distance from wall 1000 mm

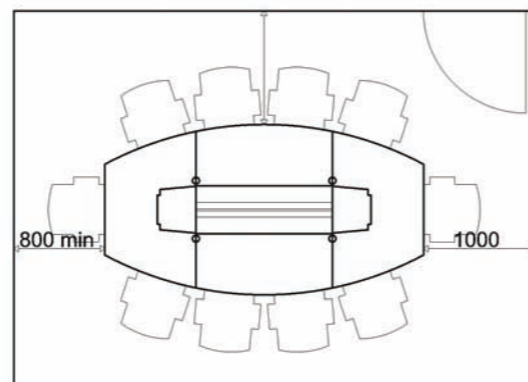

The above examples show possible custom solutions based on In-tensive components. Ask for a best custom solution for your project after particular specifications.

2d & 3d cad files available for planning purposes on our web www.inno.fi

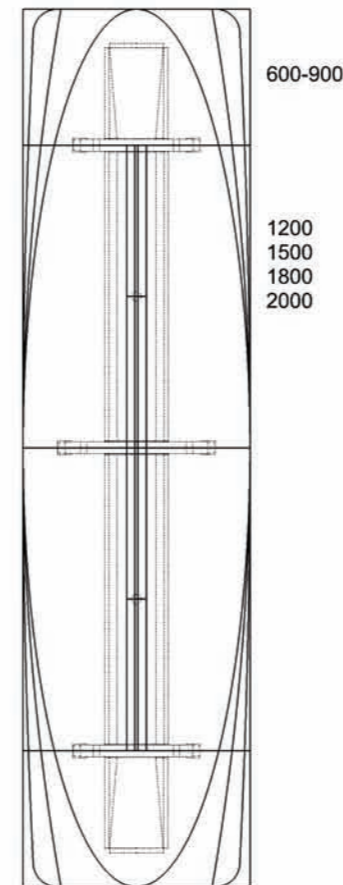
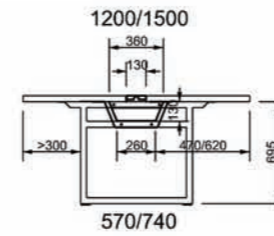

Tabletop:

- Standard shapes S (rectangular) C (boat) O (ellipse) F (rounded)
- Standard width 1200 or 1500mm (*min. 1000mm)
- Thickness 26 or 39mm
- Edge profiles (SR / VR / SVR)

Flaps:

- Length 1200 / 1500 / 1800 / 2000mm
- Access width when opened 130mm (when closed 20mm)

Cable trays:

- Trapezoid of dim 360/260h130mm in section

Legs:

- In between users, min. 300mm set back from the edge of the table (*less if table width under 1200mm)
- 8 different types in 2 widths
- Height 695mm + height adjustment glides

Materials:

- Standard materials on page 18



SR
26 or 39mm

VR
26mm

SVR
26mm

STRAIGHT EDGE VENEERED OR PAINTED MDF (26mm ONLY)

BEVELLED EDGE (STAINED OR PAINTED MDF)

BEVELLED EDGE (VENEERED STRAIGHT PART)

S1S
C1C
O1O
F1F
FLAPS 1200
60cm
8 / 10

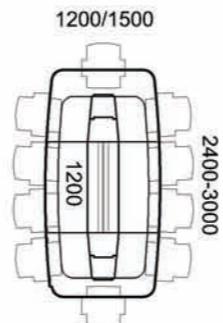
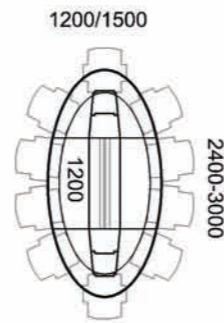
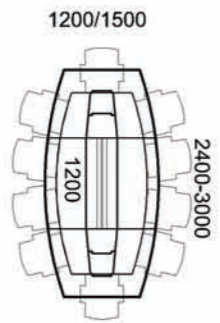
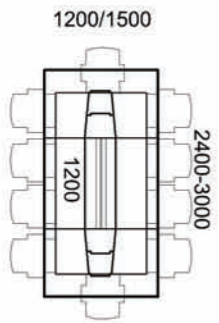

S2S
C2C
O2O
F2F
FLAPS 1200
60cm
12 / 14

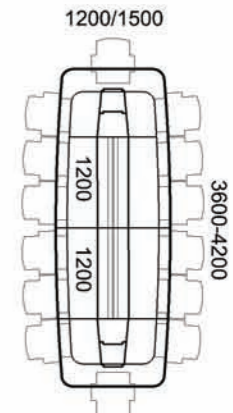
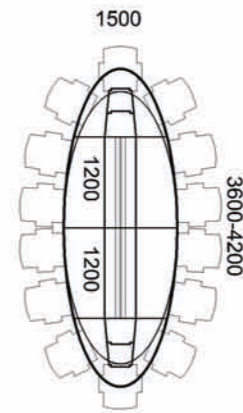
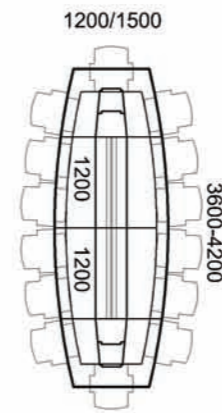
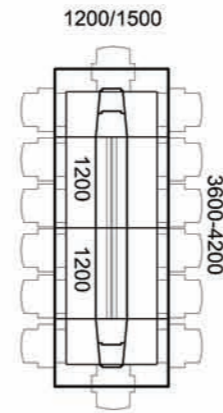

S1S
C1C
O1O
F1F
FLAPS 1500
75cm
8 / 10

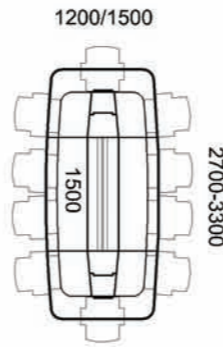
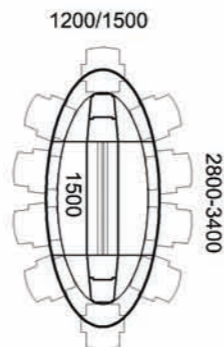
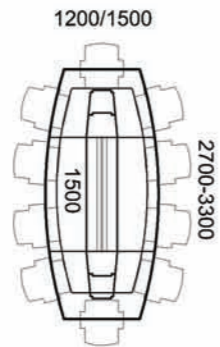
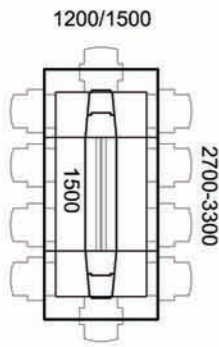

S2S
C2C
O2O
F2F
FLAPS 1500
75cm
12 / 14

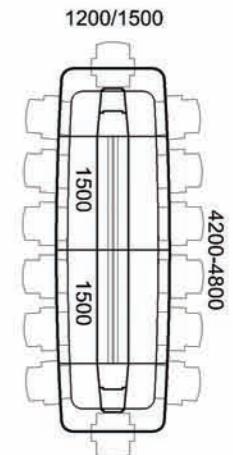
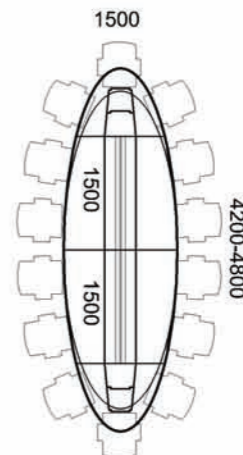
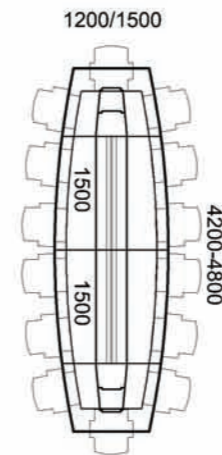
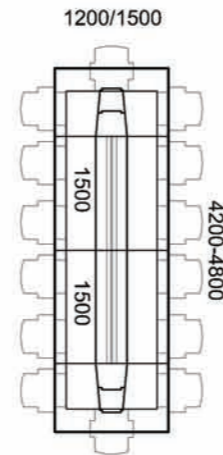

S1S
C1C
O1O
F1F
FLAPS 1800
60cm
10 / 12

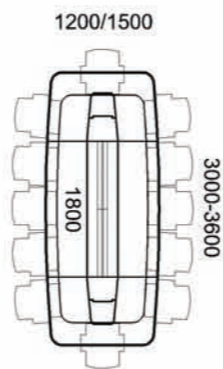
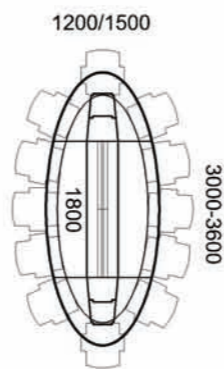
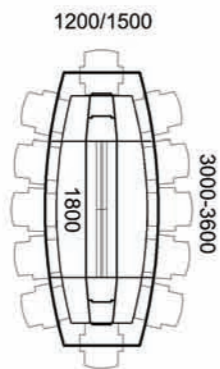
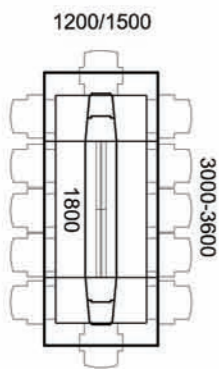

S2S
C2C
O2O
F2F
FLAPS 1800
60cm
16 / 18

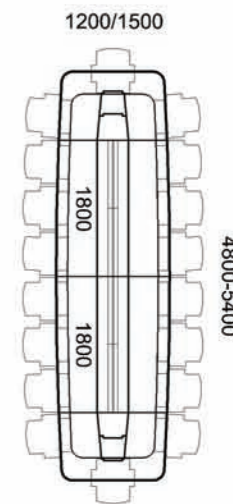
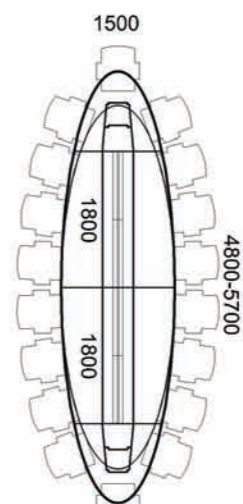
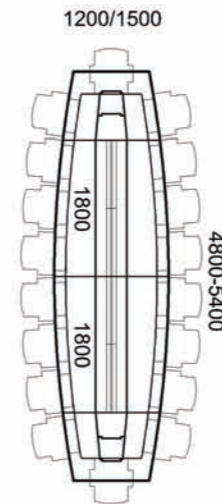
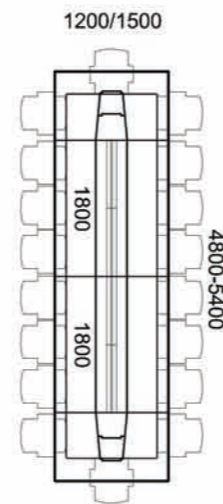

S1S
C1C
O1O
F1F
FLAPS 2000
66cm
10 / 12

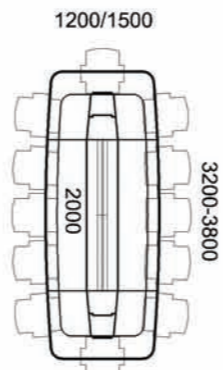
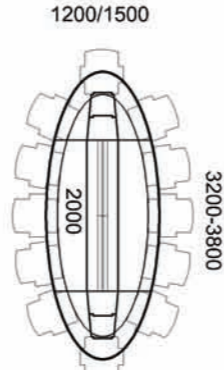
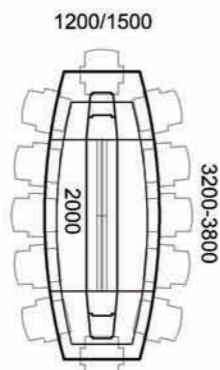
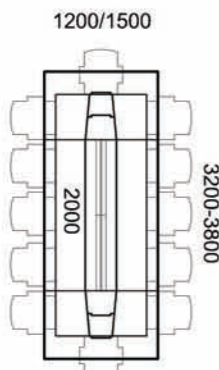

S2S
C2C
O2O
F2F
FLAPS 2000
66cm
16 / 18

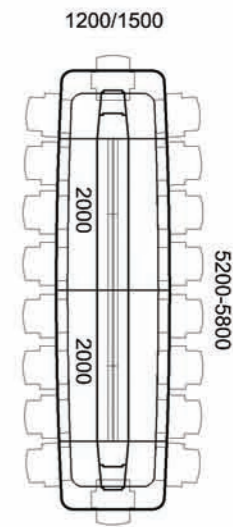
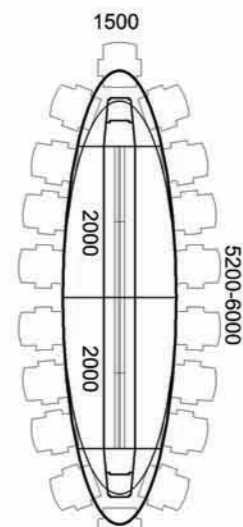
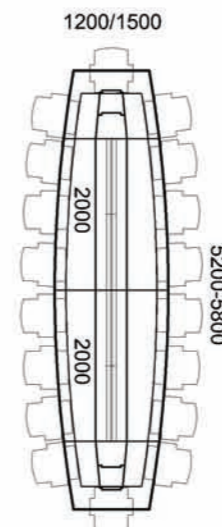
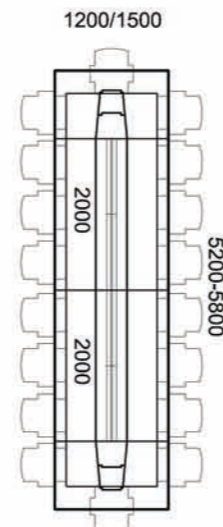

S3S
C3C
O3O
F3F

FLAPS 1200

 60cm

 16 / 18

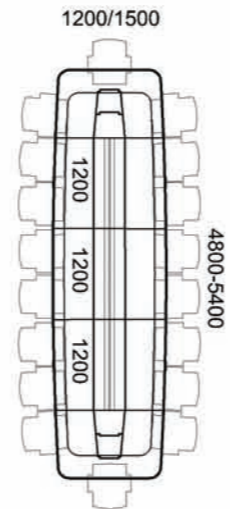
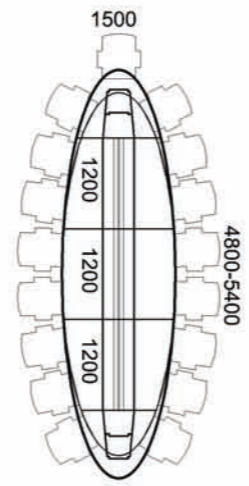
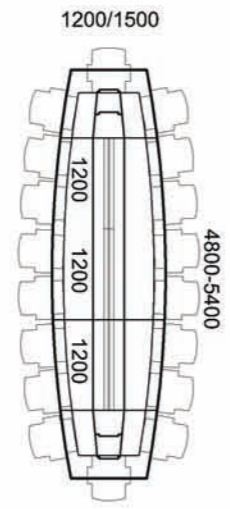
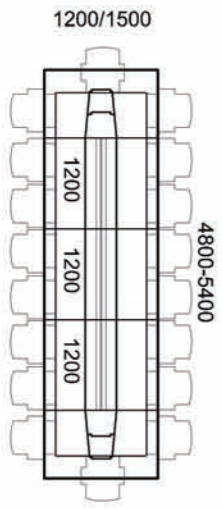

S3S
C3C
O3O
F3F

FLAPS 2000

 66cm

 22 / 24

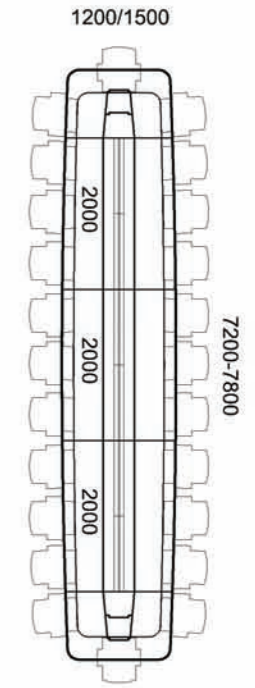
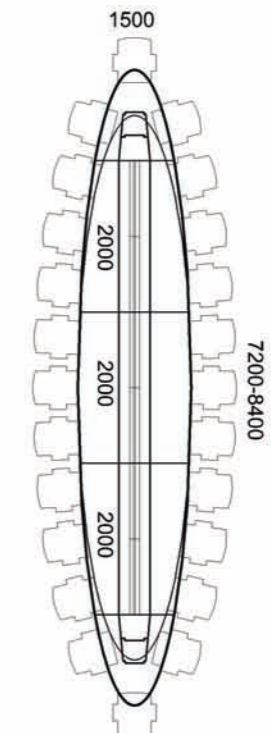
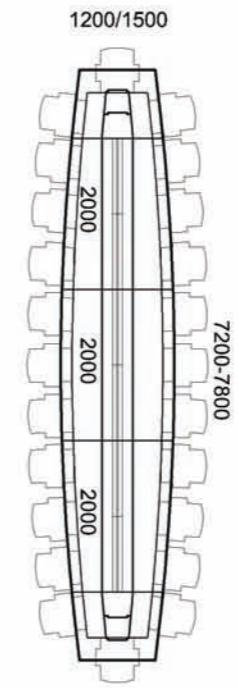
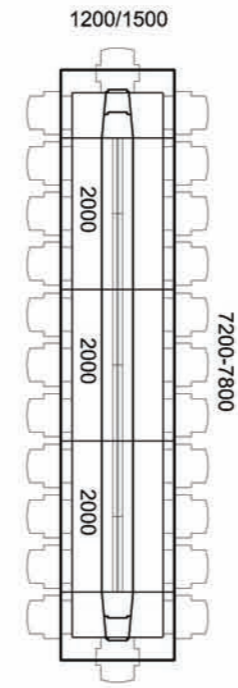

S3S
C3C
O3O
F3F

FLAPS 1500

 75cm

 16 / 18

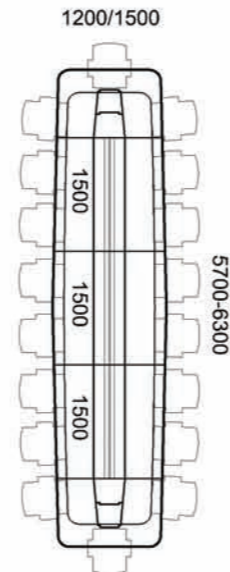
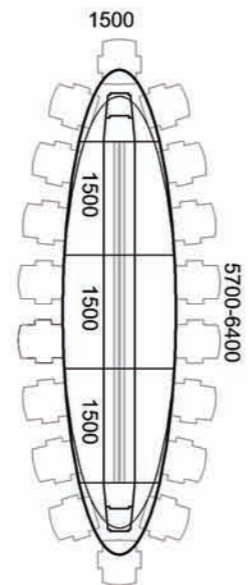
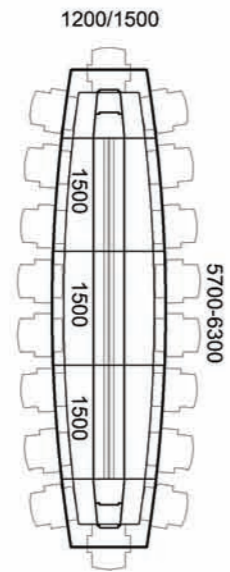
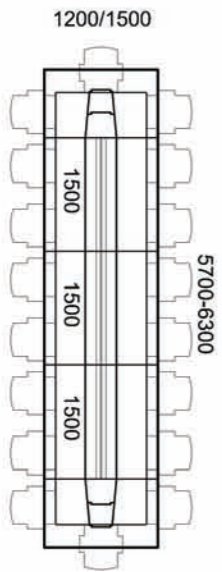

S4S
C4C
O4O
F4F

FLAPS 1200

 60cm

 20 / 22

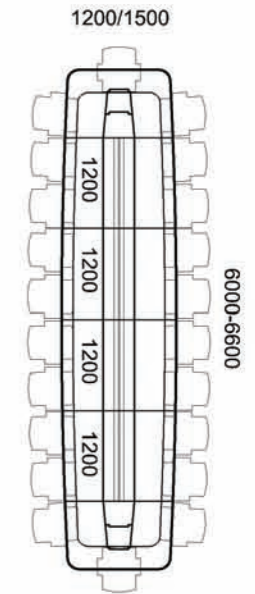
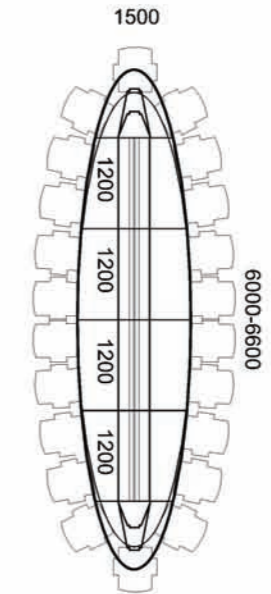
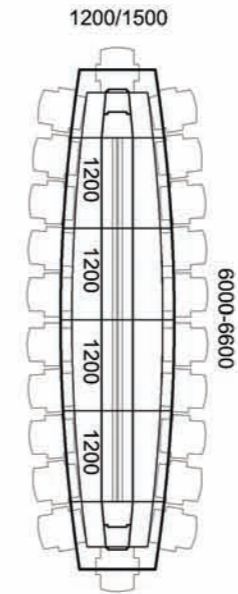
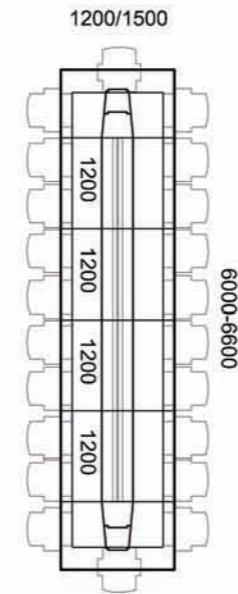

S3S
C3C
O3O
F3F

FLAPS 1800

 60cm

 22 / 24

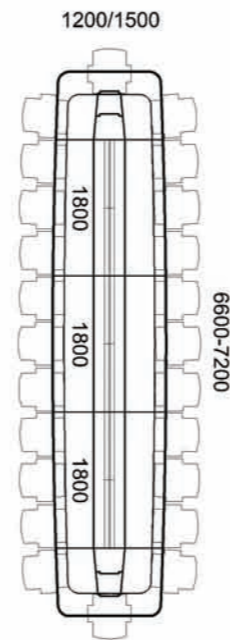
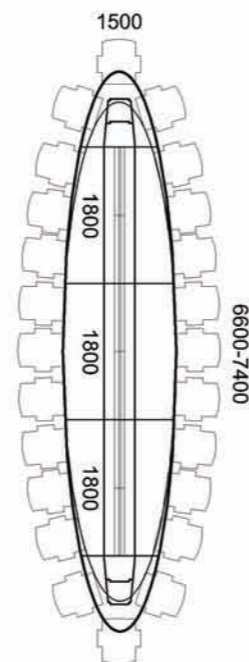
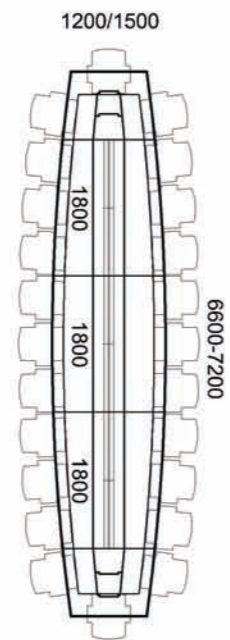
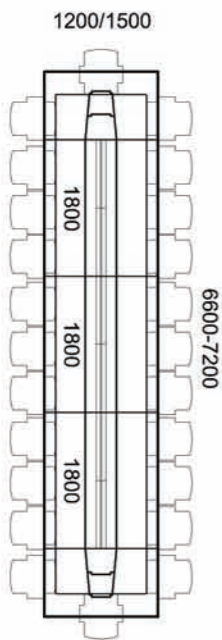

S4S
C4C
O4O
F4F

FLAPS 1500

 75cm

 20 / 22

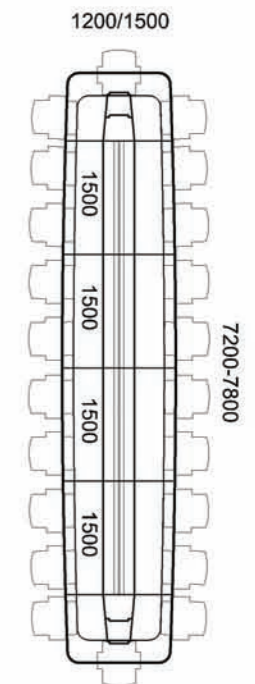
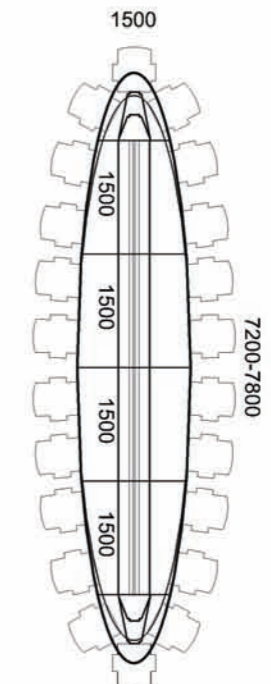
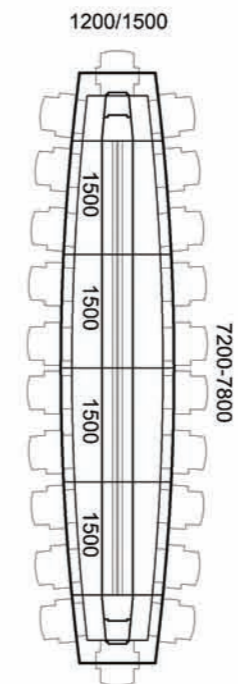
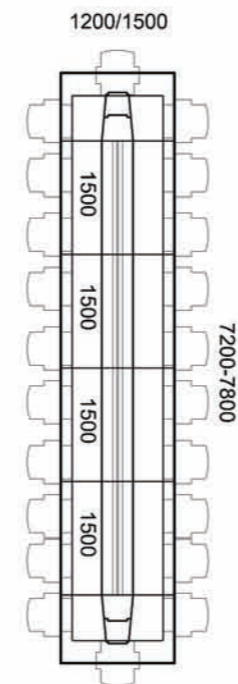

S4S
C4C
O4O
F4F

FLAPS 1800

 60cm

 28 / 30

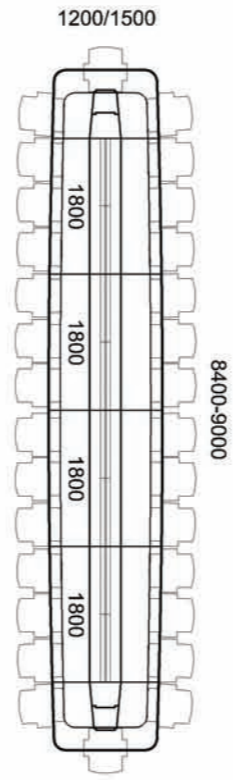
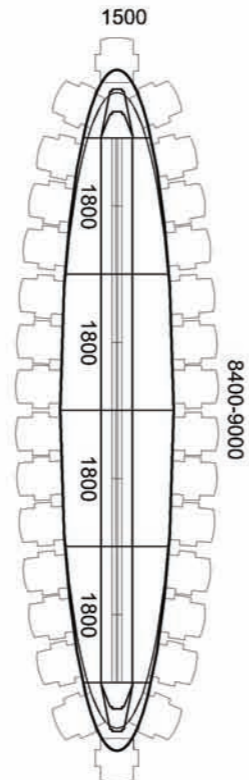
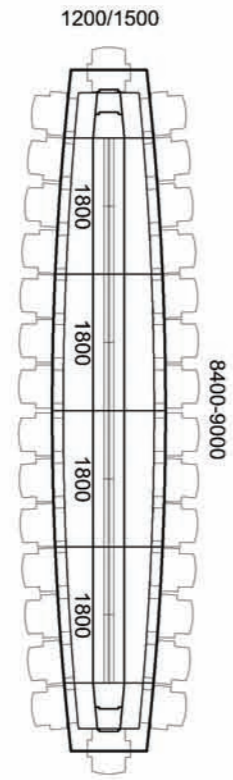
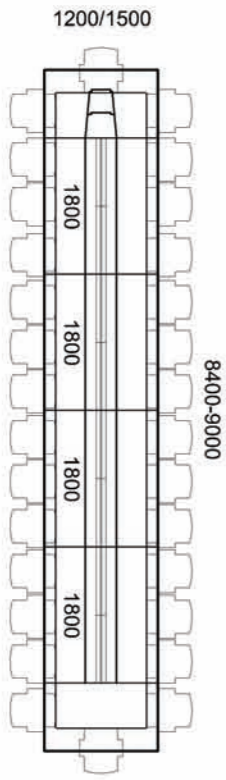

S5S
C5C
O5O
F5F

FLAPS 1200

 60cm

 24 / 26

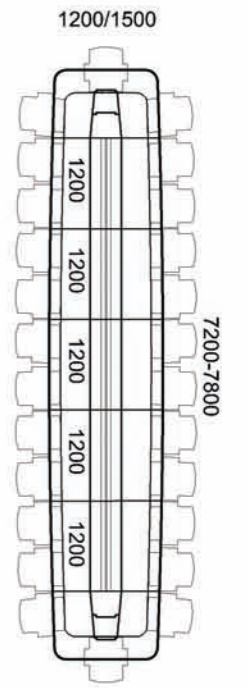
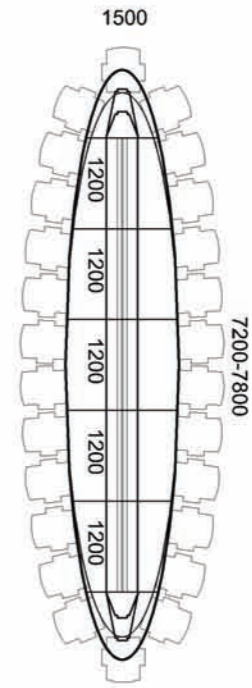
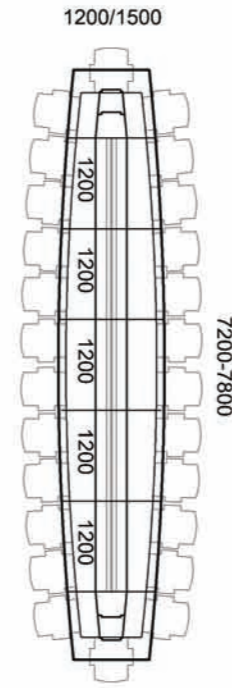
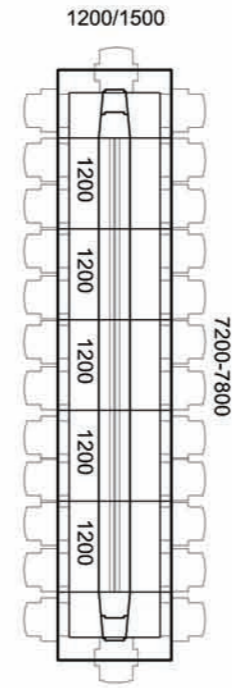

S4S
C4C
O4O
F4F

FLAPS 2000

 66cm

 28 / 30

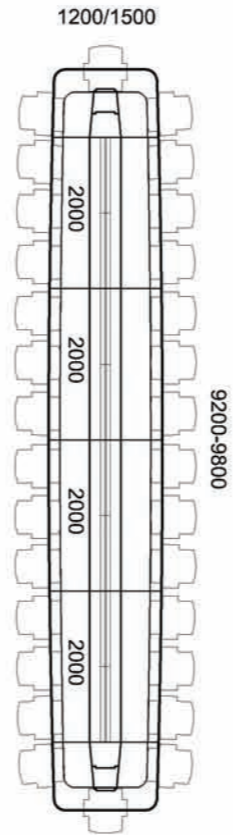
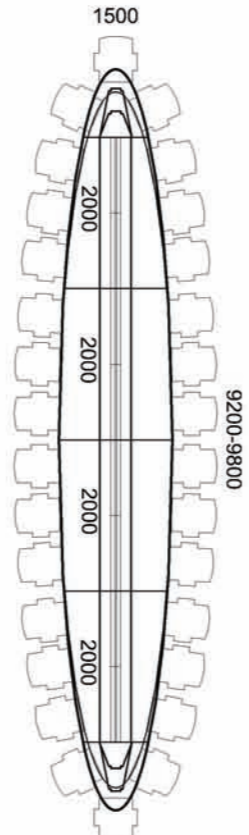
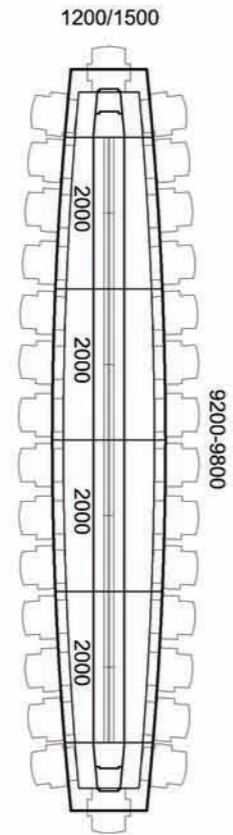
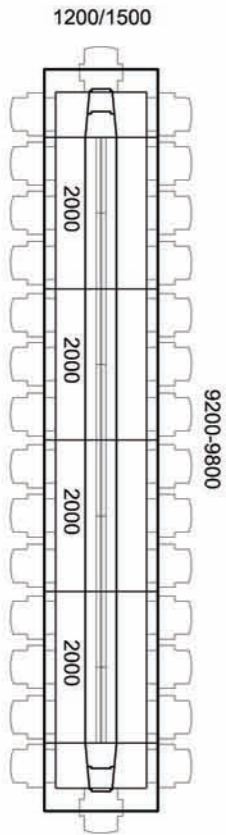

S5S
C5C
O5O
F5F

FLAPS 1500

 75cm

 24 / 26

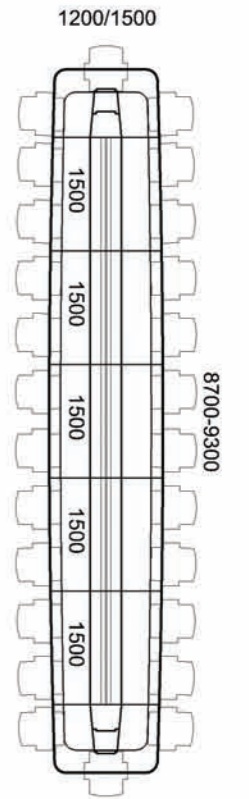
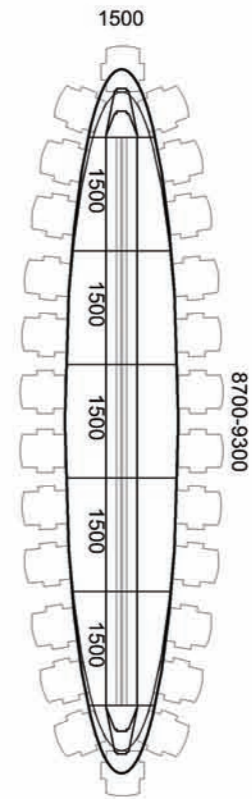
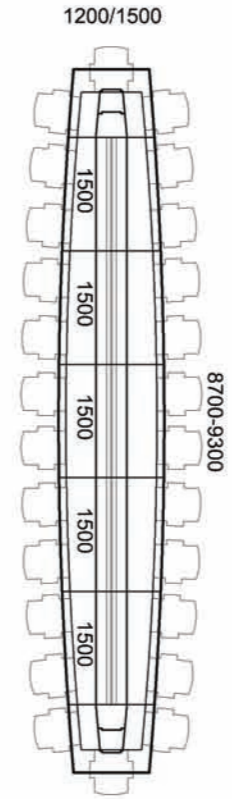
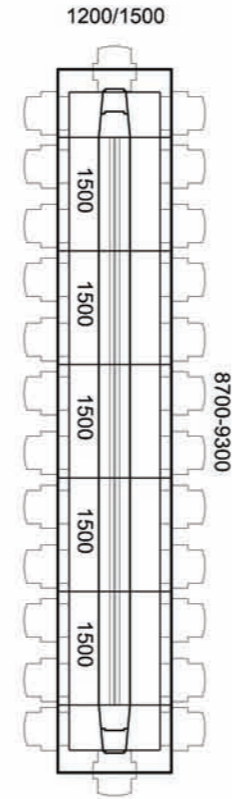

S5S
C5C
O5O
F5F
FLAPS 1800
60cm
34 / 36

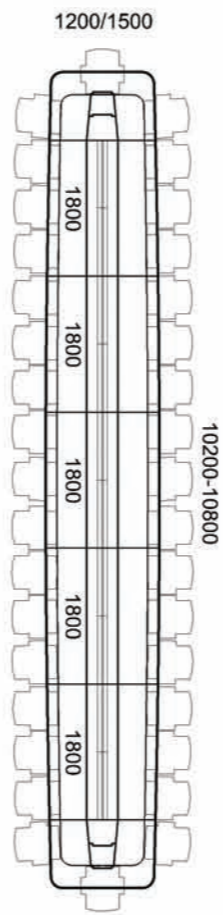
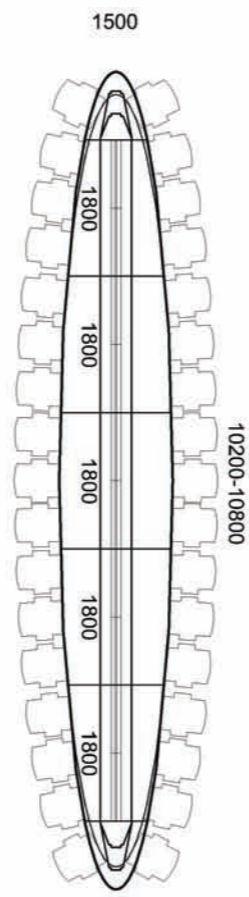
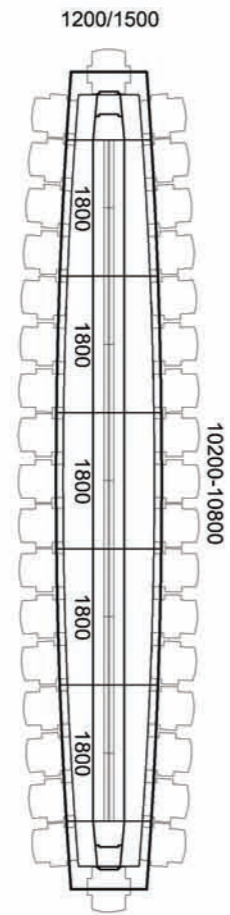
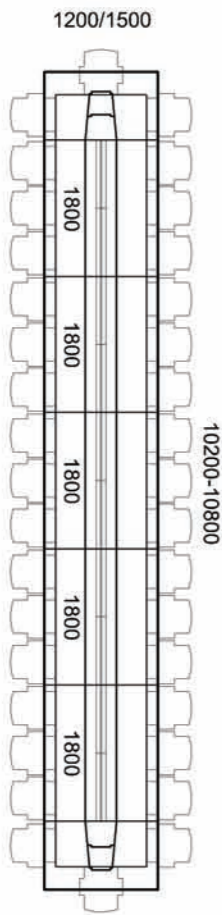

S Unit
C Unit
O Unit
F Unit
FLAPS 1800
65-70cm
8 / 10

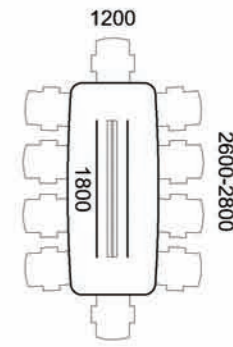
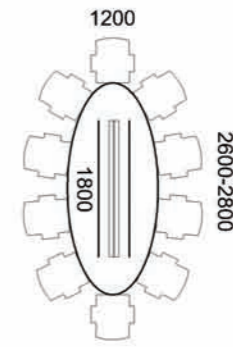
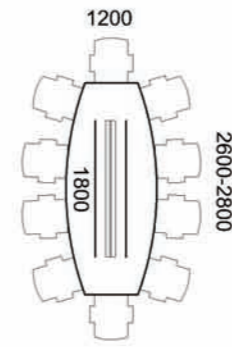
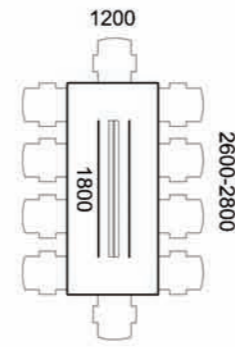

S Unit
C Unit
O Unit
F Unit
FLAPS 1500
57-62cm
8 / 10

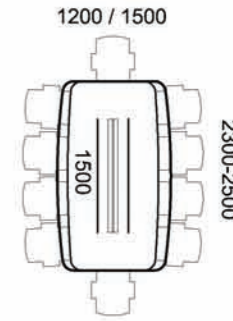
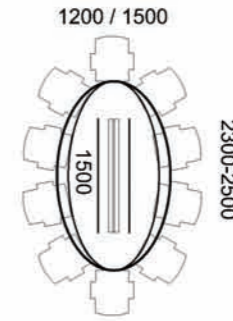
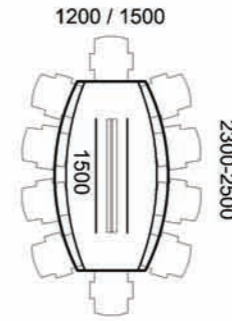
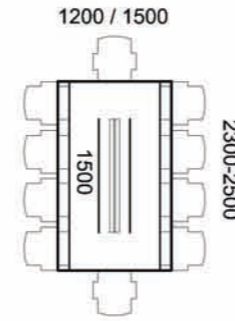

S Unit
C Unit
O Unit
F Unit
FLAPS 1200
63-73cm
6 / 8

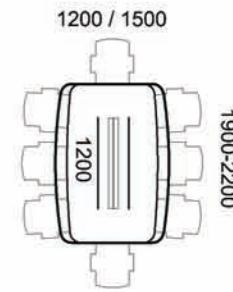
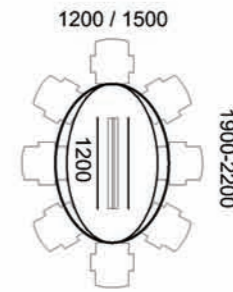
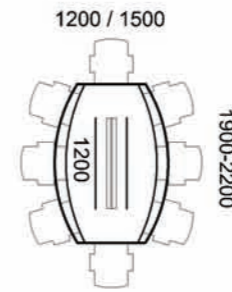
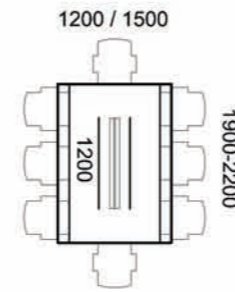

S5S
C5C
O5O
F5F
FLAPS 2000
66cm
34 / 36

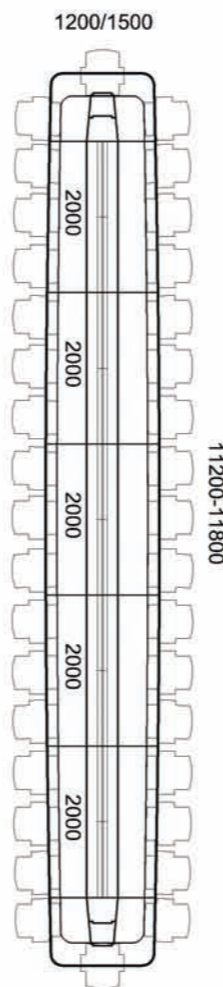
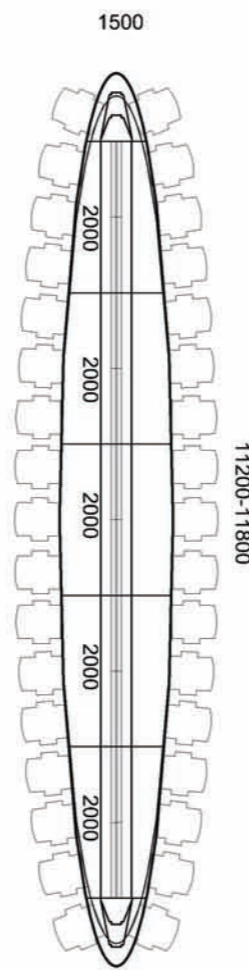
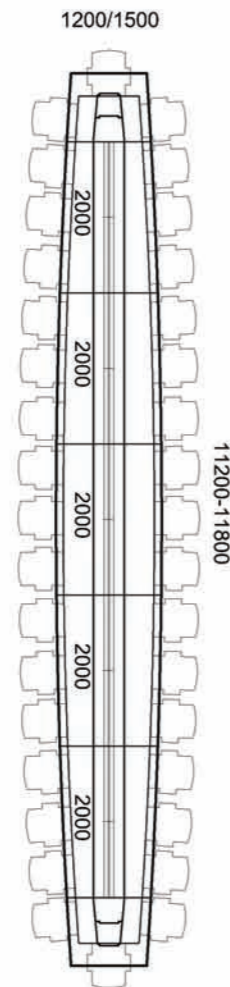
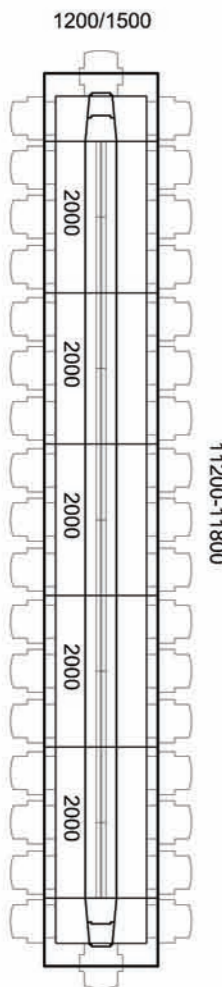

S Unit
C Unit
O Unit
F Unit
FLAPS 800
75-90cm
4 / 6

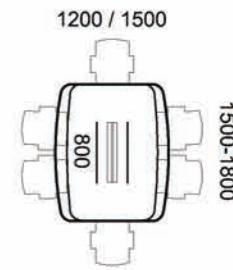
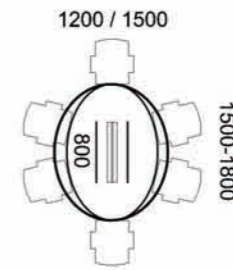
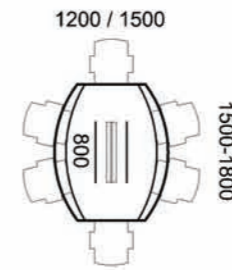
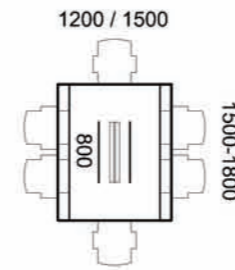

Modular
Unit (CH)
FLAPS 1000
90cm
4 / 5

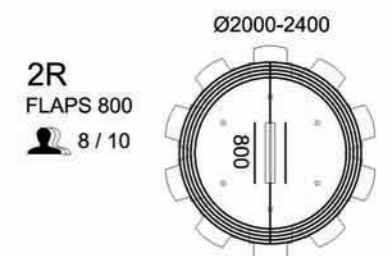
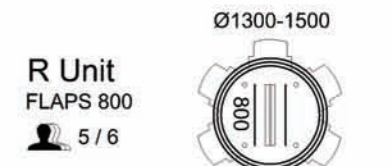
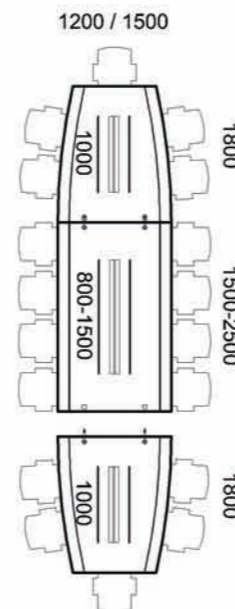

epoxia

6 avenue Charles de Gaulle
78150 Le Chesnay
+33 1 39 66 00 77
contact@epoxia.com
www.epoxia.com



Rejoignez-nous sur nos réseaux sociaux

